

4X TSO-M25-600ZI Inserts
Install from other side

4X SO-M3-18Z Inserts
Install from other side

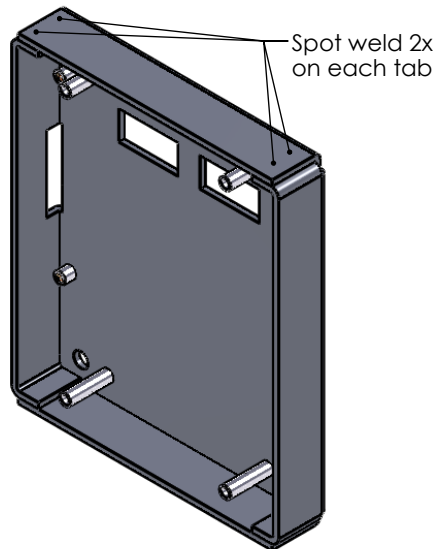
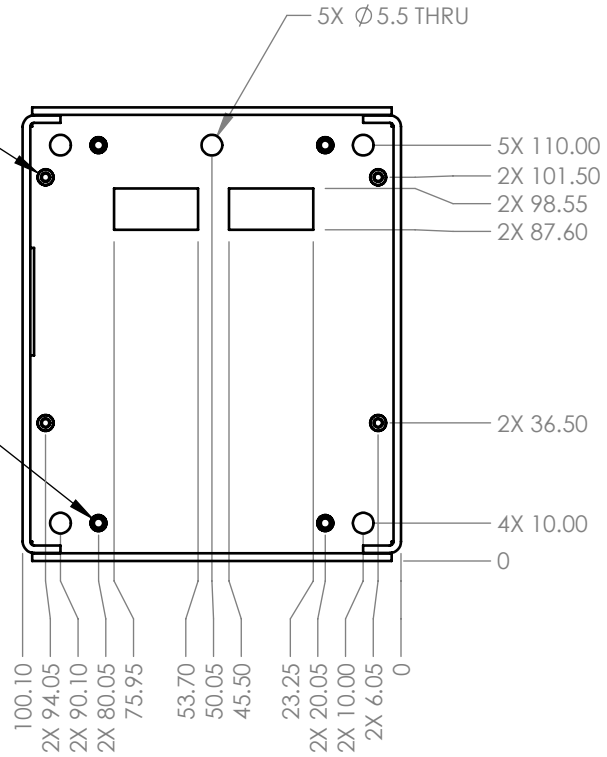

Notes:

1. Material: RoHS compliant 12AWG (.08") Aluminum
2. Part is to be Black Anodized. Mask all threads prior to coating.

DRAWN BY
SINNEMA 6/17/13

MATERIAL

UNLESS OTHERWISE SPECIFIED
DIMENSIONS ARE IN MILLIMETERS.
TOLERANCES ARE:

DECIMALS	ANGLES
.X ± .75	X° ± 1°
.XX ± .25	
.XXX ± .125	
.XXXX ± .050	63

BREAK EDGES .005/.020
FILLET RADIUS .005/.020



Sinnema Design Services

seth.sinnema@gmail.com
Phone: (303) 250-8218
Fax: 1-267-393-7872

TITLE

LCD cover back

SIZE A DWG NO.

REV. IR

SCALE 1:2 DO NOT SCALE DRAWING SHEET 1 OF 1